

USER MANUAL

NI 9759

NI Powertrain Controls Electronic Throttle Driver Module

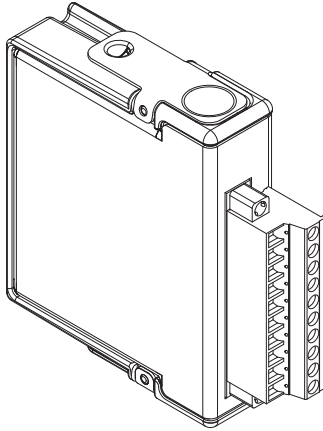

Contents

Introduction	1
Pinout	2
Hardware	2
Powering the Module	3
Platform Compatibility	3
H-Bridge Drivers	4
Analog Inputs	5
Throttle Control	7
Compliance and Certifications	9
Physical Specifications and Characteristics	11

Introduction

The National Instruments 9759 Electronic Throttle Driver Module includes a CompactRIO (cRIO) module for driving passenger car electronic throttle bodies up to 70 mm in diameter. A typical example of electronic throttle bodies which this module is capable of driving is the Bosch DV-E5 series which range from 32 mm to 68 mm in diameter. The module is capable of driving most other electronic throttle bodies within that size range.

The NI 9759 includes a LabVIEW FPGA VI for controlling two H-Bridge driver channels independently and a set of RT VIs which allow the user to calibrate the throttle control algorithm in engineering units. The FPGA VI may be used by itself for driving any small DC motor other than an electronic throttle. This manual will focus on the application of electronic throttle position control. The features included are listed below:

Features

- 2-Ch. H-Bridge Drivers for dual electronic throttle control
- 2-Ch. analog input for throttle position feedback
- Short circuit and over-temperature protection with fault reporting
- Battery voltage, current sensing and module temperature measurements
- LabVIEW FPGA VI for H-Bridge control and interface
- LabVIEW RT VI for electronic throttle position control
- External power supply of 7 V to 32 V (See *Powering the Module*)

Pinout

Figure 1. NI 9759 Pin Assignments

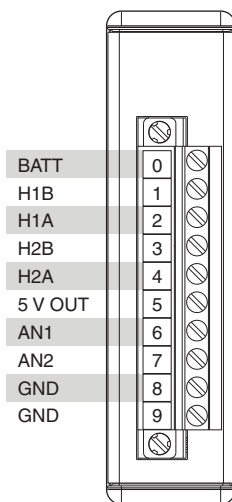

Hardware

The NI 9759 includes two H-Bridge drivers and analog position feedback in a NI CompactRIO module.

Powering the Module

The NI 9759 requires power from two different sources, the CompactRIO backplane male high density D-SUB 15-pin (HD15) connector and the external screw-terminal connector.

The HD15 connector mates with the module's female HD15 connector and provides a regulated 5 V and ground to various digital logic functions. The CompactRIO 5 V source is active whenever the CompactRIO or R Series Expansion Chassis is properly powered. The module should only be powered at the HD15 connector by plugging it into a CompactRIO or R Series Expansion Chassis. The module's HD15 connector should not be connected to any other device.

The external screw-terminal connector has terminals labeled BATT (0) and GND (9). Typical power sources will be from automotive 12 V or 24 V battery systems. The NI 9759 can accept power from a range of 7 V to 32 V. However, the H-bridge power stages have a minimum voltage requirement of 11 V. Therefore, if the module external power is in the range of 7 V to 11 V, then communication with the module will be active, but the power stage will be inactive. The active/inactive status of the power stage is not reported back to the RIO device driver. Without throttles connected, the module requires a maximum 100 mA from the external supply. Driving a single throttle under full load requires a maximum of 60 W peak and 30 W continuous. Driving two throttles at full load requires a maximum 120 W peak and 60 W continuous.

The NI 9759 requires both external power and power from the CompactRIO backplane. The NI 9759 directs the high current path through the BATT (0) and GND (9) terminals on the front of the NI 9759 and not through the HD15 backplane connector.



Note The NI 9759 will not be recognized by software without both power supplies active.



Caution The external battery supply input terminals are not reverse voltage polarity protected. Connecting power to the NI 9759 in reverse polarity will cause damage. This event is not covered by the warranty.

Platform Compatibility

NI Powertrain Control modules require a hardware support system to function. You cannot use the modules independently or interfaced with third-party devices at the backplane HD15 connector. NI Powertrain Control modules are compatible with the following National Instruments platforms:

- CompactRIO, which consists of a CompactRIO controller, chassis, or integrated controller/chassis.
- NI PXI, which consists of any NI PXI chassis, NI PXI RT controller, and NI PXI-78xxR R Series FPGA card. The NI Powertrain Control modules insert into an NI R Series expansion chassis. Connect an NI R Series expansion chassis to the NI PXI FPGA card using a SHC68-68-RDIO cable.



Note NI Powertrain Control modules are not compatible with the National Instruments CompactDAQ chassis.

You can use NI Powertrain Control modules with NI cRIO-911x, NI cRIO-907x, and NI R Series Expansion systems under the following conditions:

- Leave one empty chassis slot between NI Powertrain Control modules and other NI modules.
- Maintain an ambient system operating temperature of 0 °C to 45 °C.



Note Typical specifications of National Instruments modules might not apply when used in a system with NI Powertrain Control modules.



Note National Instruments guarantees warranted specifications for all National Instruments modules except thermocouple modules when used in a system with NI Powertrain Control modules.



Note National Instruments recommends the NI 9214 for thermocouple measurements in CompactRIO systems using NI Powertrain Control modules.



Note NI Powertrain Control modules do not support Scan Interface mode, auto-detection, or ID mode.

H-Bridge Drivers

The NI 9759 includes a CompactRIO (cRIO) module for driving passenger car electronic throttle bodies up to 70 mm in diameter. A typical example of electronic throttle bodies which the NI 9759 is capable of driving, is the Bosch DV-E5 series which range from 32 mm to 68 mm in diameter. The NI 9759 is capable of driving most other electronic throttle bodies within that size range.

Each H-Bridge circuit is capable of driving 3 A continuously and a 6 A peak. It provides current sensing feedback as well as over-current and over-temp protection. In the case of a short circuit, where 10 A is exceeded or a temperature of 140 °C is exceeded within the driver FETs, a fault flag will be generated and the circuit will shutdown until the fault condition is removed. Monitor the current and temperature values and disable the circuit programmatically if current exceeds 6 A or the internal module temperature exceeds 85 °C. The temperature is automatically monitored within the `throttle_rt_control.vi`.

Each H-Bridge circuit automatically eliminates shoot-through current and provides internal clamp diodes for inductive loads.

Analog Inputs

The NI 9759 provides two external analog inputs for accepting 0 V to 5 V signals. The primary purpose of these inputs is for measuring potentiometer voltages. A regulated 5 V output and ground terminal is provided for powering the potentiometer(s) of an electronic throttle body.



Caution The 5 V output is not protected against short circuit to higher voltage sources. Do not short this terminal to the H-Bridge driver terminals or BATT terminal.

Other analog signals are also measured internal to the module and reported by the supplied VIs. All measured analog signals are listed below:

- Battery Voltage (V)
- H-Bridge 1 Current (A)
- H-Bridge 2 Current (A)
- H-Bridge 1 Fault Line (reported with boolean, T=Fault, F=No Fault)
- H-Bridge 2 Fault Line (reported with boolean, T=Fault, F=No Fault)
- External Analog Input 1 (0 V to 5 V, Screw-Terminal 6)
- External Analog Input 2 (0 V to 5 V, Screw-Terminal 7)
- Internal Temperature

All eight analog inputs are sampled with a single multiplexed A/D converter at an aggregate rate of 17.84 kHz. Each analog signal is sampled at 2.23 kHz. The A/D result can be used directly at the FPGA level in ADC counts or at the RT level in converted engineering units.

The external analog inputs are protected from -6 V to +12 V inputs.

The external analog inputs are for connecting all wires of an electronic throttle directly to the NI 9759. You can programmatically use the analog values for throttle control feedback. Other analog inputs from another module may also be used to provide throttle position. Most electronic throttle bodies have redundant position signals. When using only one electronic throttle, both position signals may be connected to the NI 9759 and redundant throttle position is available. When two electronic throttle bodies are used, only one position signal from each throttle may be connected to the NI 9759, and redundant throttle position is not available. The additional position signals may be connected to other analog inputs from other modules, making redundant throttle position available for both throttles. A redundant position algorithm must be provided by the user.

Figure 2 and 3 below show the typical connections for controlling single or dual throttles, respectively. Table 1 below shows the terminal connections to a standard Bosch DV-E5 electronic throttle body.

Figure 2. Terminal Connections to a Single Electronic Throttle Body

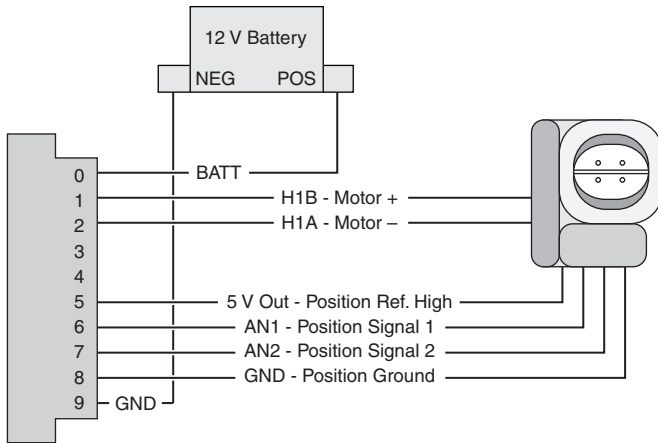

Figure 3. Terminal Connections to Dual Electronic Throttle Bodies

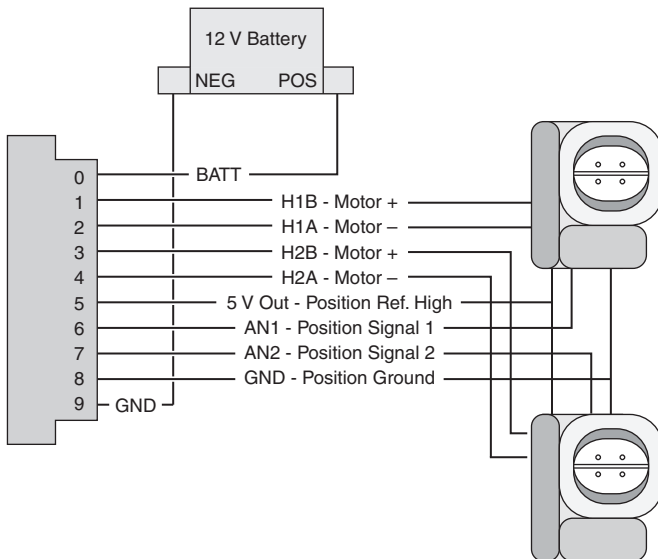

Table 1. Connection Table Specific for Standard Bosch DV-E5 Electronic Throttle Bodies

DV-E5 Pin	Description	Module Terminal (Throttle1/Throttle2)	Description
1	Motor -	T2/T4	H1A/H2A
2	Potentiometer Ground	T8	GND
3	Potentiometer Reference	T5	5V Out
4	Motor +	T1/T3	H1B/H2B
5	Potentiometer 2 Signal	T6/T7	AN1/AN2
6	Potentiometer 1 Signal	T6/T7	AN1/AN2

Table 2. Standard Bosch DV-E5 Throttle Bodies

Throttle Body Diameter (mm)	Bosch Part Number
32	0 280 750 148
40	0 280 750 149
54	0 280 750 150
60	0 280 750 151
68	0 280 750 152

Visit ni.com/info and enter Info Code `THROTTLE` for more information about parts and accessories for the NI 9759.

Throttle Control

NI provides a flexible throttle position control algorithm with the NI 9759. Follow the throttle control example included in the driver package for implementing throttle control in your engine control application. Perform throttle control at a rate of 100 to 200 Hz, even if your engine control algorithms require execution at another rate, a separate timed loop can be created to implement throttle control. The throttle control VI uses position values in terms of degrees, but percentages can be used instead.

The throttle control algorithm calculates a final voltage to be applied to the throttle body DC motor. The final voltage is applied by means of a PWM duty cycle, with battery voltage being the maximum possible voltage. The control voltage may be compensated for actual battery voltage, if it deviates from the nominal battery voltage, according to `BattCompEnable`. The compensated voltage is converted to a signed PWM duty cycle at a fixed frequency of 500 Hz. The throttle control VI output results are in terms of 40 MHz clock ticks to be wired to the FPGA period and pulse width parameters.

The throttle control algorithm involves four major functions:

1. The angle setpoint (reference), ThetaR is compensated by a user defined lead and lag time. These parameters will sharpen or dull the changes in setpoint.
2. A proportional, integral and derivative action is calculated based on two sets of PID gains, above or below the default limp-home region. The reason for two sets of gains is because electronic throttle bodies typically have stiffer spring return rates applied to angles below the limp-home region.
3. A limp-home compensation value is added to the PID value to assist with travel through the limp-home region. This compensation can minimize the flat control spot often found as the throttle plate moves through the limp-home region.
4. A stiction compensation value is added to the PID value to assist with small error control. When the throttle plate approaches the setpoint, stiction in the throttle motor gearing can be significant enough such that PID control alone will cause integral overshoot. Stiction compensation will apply small alternating forces to assist the PID integral action.
5. Battery voltage compensation is optionally added to the final output to compensate for battery voltage fluctuations away from the nominal voltage.

In general, the final voltage u (V) is a sum of three components and optionally multiplied by a battery compensation factor:

$$u(V) = [\text{PID}(V) + \text{Stiction Comp}(V) + \text{Limp-Home Comp}(V)] \times \text{Battery Comp Factor}$$

The first calibration which the user should tune is throttle angle versus sensor voltage. A linear equation can be used, as well as a two-point 1D lookup table.

1. Manually close the throttle plate completely to determine the minimum sensor voltage. If the radii of the throttle body opening and the throttle plate are measured, then the minimum throttle angle can be calculated by using an inverse cosine calculation, or by approximating the small angle with sine.
2. Manually open the throttle plate to wide-open-throttle, noting the maximum sensor voltage.
3. Assume the wide-open-throttle angle to be 90 degrees.
4. After calibrating for position versus voltage, enter the value for ThetaLH (default limp-home position). It is recommended that the sensor voltages entered into the position calibration for the upper and lower limits be slightly narrowed so that position control at these points does not overwork the driver, trying to achieve positions that are not possible as sensing conditions change. Another way to prevent this condition is to limit the setpoint range to a small position away from the physical limits.
5. Implement a filter on throttle position. A second order, lowpass Butterworth filter with a cutoff frequency of 25 Hz is suggested. The filter is most effective during small-error control.
6. The `throttle_rt_data_convert_revx.vi` already implements a 25 Hz filter on the analog input voltages. If this VI is used for position, a filter is not required.
7. Begin control calibration with zero for all Lead/Lag, PID and compensation calibration parameters.
8. Begin tuning PID gains for angles above ThetaLH.

9. Introduce TLead and TLead values as necessary.
10. Begin tuning PID gains for angles below ThetaLH. ULH and US compensation should be tuned last. The default values saved for the example application were derived for a 68 mm Bosch DV-E5 throttle body. The default values will work well for smaller throttle bodies, with minor adjustments.



Note ThetaR should not be allowed to exceed the minimum and maximum angles of the throttle. This will force the controller to drive more current than the throttle or module can sustain. The force exerted may also mechanically damage the throttle body.

Compliance and Certifications

Safety

This product meets the requirements of the following standards of safety for electrical equipment for measurement, control, and laboratory use:

- IEC 61010-1, EN 61010-1
- UL 61010-1, CSA 61010-1

Electromagnetic Compatibility

This product meets the requirements of the following EMC standards for electrical equipment for measurement, control, and laboratory use:

- EN 61326-1 (IEC 61326-1): Class A emissions; Industrial immunity
- EN 55011 (CISPR 11): Group 1, Class A emissions
- AS/NZS CISPR 11: Group 1, Class A emissions
- FCC 47 CFR Part 15B: Class A emissions
- ICES-001: Class A emissions



Caution When operating this product, use shielded cables and accessories.

CE Compliance

This product meets the essential requirements of applicable European Directives as follows:

- 2006/95/EC; Low-Voltage Directive (safety)
- 2004/108/EC; Electromagnetic Compatibility Directive (EMC)

Environmental Management

NI is committed to designing and manufacturing products in an environmentally responsible manner. NI recognizes that eliminating certain hazardous substances from our products is beneficial to the environment and to NI customers.

For additional environmental information, refer to the *Minimize Our Environmental Impact* web page at ni.com/environment. This page contains the environmental regulations and directives with which NI complies, as well as other environmental information not included in this document.

Waste Electrical and Electronic Equipment (WEEE)



EU Customers At the end of the product life cycle, all products *must* be sent to a WEEE recycling center. For more information about WEEE recycling centers, National Instruments WEEE initiatives, and compliance with WEEE Directive 2002/96/EC on Waste and Electronic Equipment, visit ni.com/environment/weee.

Battery Replacement and Disposal



Battery Directive This device contains a long-life coin cell battery. If you need to replace it, use the Return Material Authorization (RMA) process or contact an authorized National Instruments service representative. For more information about compliance with the EU Battery Directives 2006/66/EC about Batteries and Accumulators and Waste Batteries and Accumulators, visit ni.com/environment/batterydirective.

电子信息产品污染控制管理办法（中国 RoHS）



中国客户 National Instruments 符合中国电子信息产品中限制使用某些有害物质指令 (RoHS)。关于 National Instruments 中国 RoHS 合规性信息, 请登录 ni.com/environment/rohs_china。(For information about China RoHS compliance, go to ni.com/environment/rohs_china.)

Ferrite Requirement for EMC Compliance

Install clamp-on ferrite beads onto both the power supply cable and the signal cables. Power to the module must be off when adding ferrites. Ferrites must be connected to the power cable and the signal cable as close to the module as possible. Placing the ferrite elsewhere on the cable noticeably impairs its effectiveness. Determine the clamp-on ferrite beads to install based on your application. Use the following ferrites or other similar ferrites:

- Power cables to CompactRIO and module: Laird 28A0592-0A2 (2 total)
- AN1, AN2, GND: Würth Electronics 7427154 (four turns through ferrite)
- H1B, H1A, H2B, H2A: Würth Electronics 7427154 (four turns through ferrite)

Physical Specifications and Characteristics

Weight	145 g (5.11 oz)
Maximum Altitude.....	2000 m
Operating Temperature	-40 °C to 70 °C
Maximum Ambient Temperature.....	60 °C
Operating Humidity	10% to 90% RH, noncondensing
Pollution Degree	2
Ingress Protection	IP30

For indoor use only.

If you need to clean the module, wipe it with a dry towel.

Safety Guidelines



Caution Do not operate the NI 9759 in a manner not specified in these operating instructions. Product misuse can result in a hazard. You can compromise the safety protection built into the product if the product is damaged in any way. If the product is damaged, return it to National Instruments for repair.

Refer to the *NI Trademarks and Logo Guidelines* at ni.com/trademarks for more information on NI trademarks. Other product and company names mentioned herein are trademarks or trade names of their respective companies. For patents covering NI products/technology, refer to the appropriate location: **Help»Patents** in your software, the `patents.txt` file on your media, or the *National Instruments Patents Notice* at ni.com/patents. You can find information about end-user license agreements (EULAs) and third-party legal notices in the `readme` file for your NI product. Refer to the *Export Compliance Information* at ni.com/legal/export-compliance for the NI global trade compliance policy and how to obtain relevant HTS codes, ECCNs, and other import/export data. NI MAKES NO EXPRESS OR IMPLIED WARRANTIES AS TO THE ACCURACY OF THE INFORMATION CONTAINED HEREIN AND SHALL NOT BE LIABLE FOR ANY ERRORS. U.S. Government Customers: The data contained in this manual was developed at private expense and is subject to the applicable limited rights and restricted data rights as set forth in FAR 52.227-14, DFAR 252.227-7014, and DFAR 252.227-7015.

© 2013–2016 National Instruments. All rights reserved.